

Directional Control Valves 4D01

THIS PAGE INTENTIONALLY LEFT BLANK

VELJAN model V4D01 direct operated Directional Control valves conform to NFPA D03, NG 6 (CETOP 03) standard interface. These are subplate and manifold mounted and can be used in conjunction with stack valve system. The valve mounting interface and electrical connection methods conform to international standards CETOP, ISO, DIN. The coils used in the wet pin design solenoids are available in A.C. and D.C. voltages and are continuously rated. Precise guide for all types of spools are achieved by uniquely designed five annuli body. Spools are interchangeable and no selective assembly is necessary.

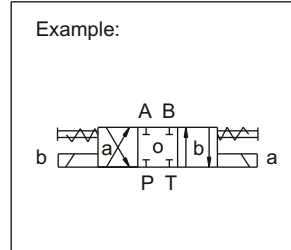

Features

- ◆ Low pressure drop for reduced heat loss and increased efficiency.
- ◆ Compact five annuli body design.
- ◆ Mounting configuration according to CETOP R35H, ISO 4401 and DIN 24340
- ◆ Wide variety of spool types including detent, and interchangeable spools and bodies.
- ◆ Actuated by electrical / hydraulic / pneumatic / cam or lever mechanism.
- ◆ Wide range of A.C. and D.C. coil voltages are available both with or without manual override.
- ◆ Low electrical power consumption (29 W / 24 V DC)
- ◆ Quick change of solenoid coil without risk of oil leakage.
- ◆ Solenoid coil can be positioned at 90° intervals with respect to body .
- ◆ Upto 210 bar pressure allowable at tank port .
- ◆ Electrical connection by standard 3 pin connector according to DIN 43650 , ISO 4400 or with Wiring box.
- ◆ Optional plug-in connector with LED display are available.
- ◆ Every valve is factory tested prior to despatch.

DC

OPERATION

The Directional Control valve V4D01 consists of a body, spool and either one or two actuators depending upon the application. The spool is shifted by the action of electrical solenoid, mechanical, hydraulic, pneumatic, cam or lever actuator mechanism. Spool movement allows oil under pressure from port P to flow to either port A or B, and subsequently connect the other port to tank. On de-energizing the actuator, the spool is returned to the center position or offset position. Manual operation of spool is possible using the optional manual override system.

**Brad Harisson or
(Optional) Cannon
14S Connector**

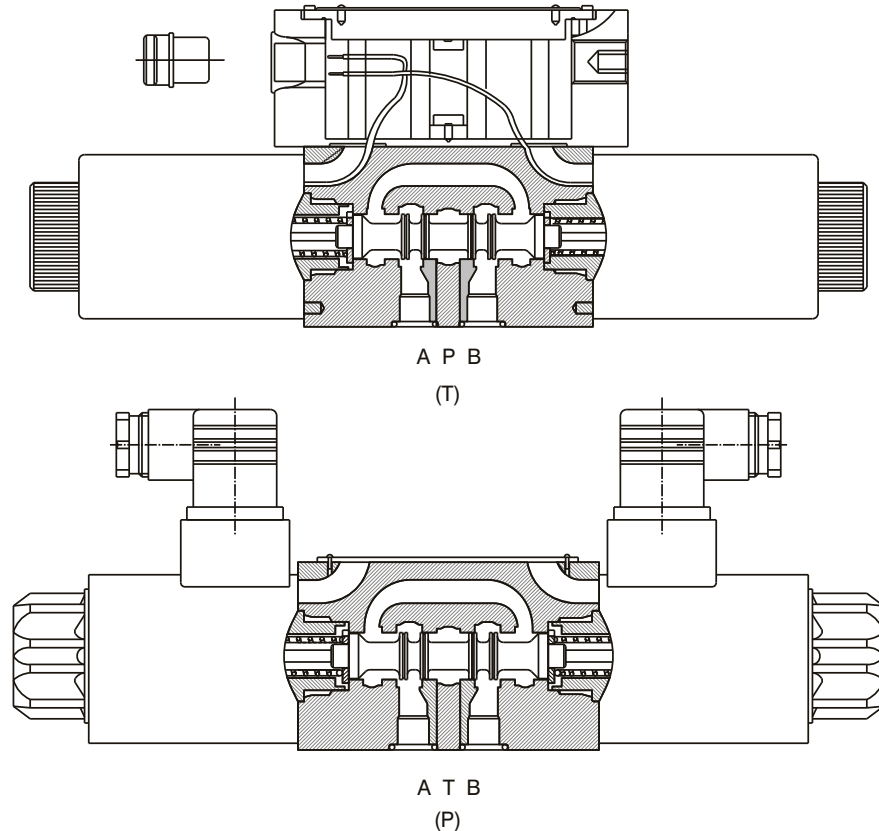

DC

Orifice

Depending on the operating conditions flow from the valve can be limited by using orifice plug at port P. Consult model code for orifice sizes.

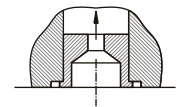

Characteristics

Design	Sliding spool valve
Type of Mounting	Subplate
Mounting Position	Optional but horizontal recommended
Ambient temperature range	0....120°F (-18 +50°C)
Operating Pressure(P,A,B)	350 bar (5000 psi)
Permissible pressure T	up to 210 bar (3000 psi)
Max. flow	21,1 GPM(80 l/min.) (see diagram - Pressure drop curves)
Fluid	Mineral oil according to DIN 51524 and 51525
Viscosity range	10....650 cSt, optimum 30 cSt
Fluid temperature range	0....176°F(-18.... +80°C)
Contamination level	Max. permissible contamination level according to NAS 1638 Class 8 (Class 9 for 15 Micron and smaller or ISO 17/14)

SOLENOID CHARACTERISTICS

	A.C.	D.C.
Nominal Voltage	see ordering code	see ordering code
Power Input	20 W	29 W
Holding Power	45 VA	
Inrush Power	199 VA	
Permissible Voltage difference	± 10%	± 10%
Maximum coil temperature	135 °C (275° F)	105 °C (220° F)
Relative Operating Period	100%	100%
Type of Protection	IP 65	IP 65
Insulation Class	H	F
Cycle (1/H)	14400	14400

PRESSURE DROP

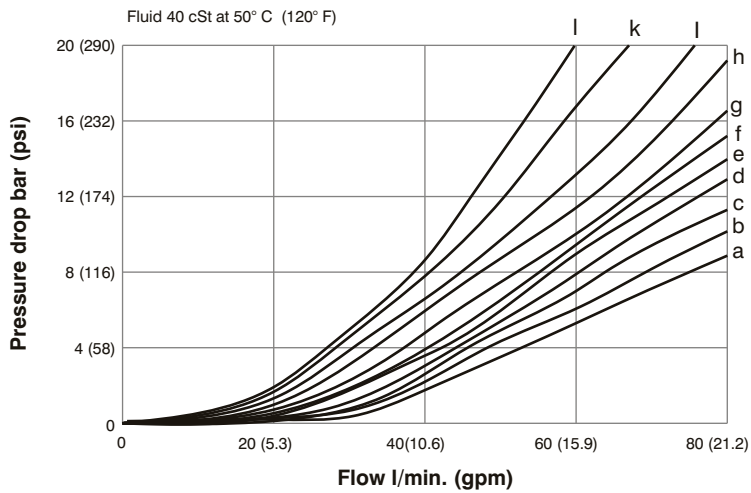

Performance data given is typical and can be influenced by application.

DC

	Spool Type																				
	01	02	03	07	08	09	10	11	12	46	51	52	55	56	64	65	81	91	0C	0Y	0X
P → A	a	e	d	l	d	c	c	c	h	a	e	f	g	g	h	l	b	l	k	a	b
P → B	a	e	d	l	d	c	c	c	h	a	e	f	g	g	l	h	b	l	k	a	b
P → T	b	-	-	l	-	-	-	-	-	-	-	-	-	-	k	k	-	-	k	-	-
A → T	c	c	d	l	a	e	a	d	-	g	g	-	f	-	k	l	e	d	-	e	c
B → T	c	c	d	l	b	a	e	d	-	g	g	-	-	f	l	k	e	d	-	e	c

SPOOL POSITIONS

Spring Centered

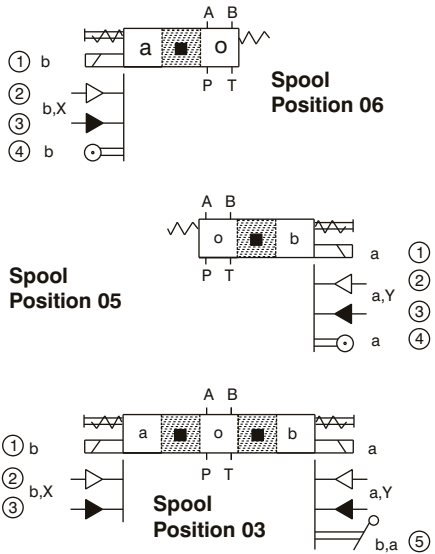

Spring Offset

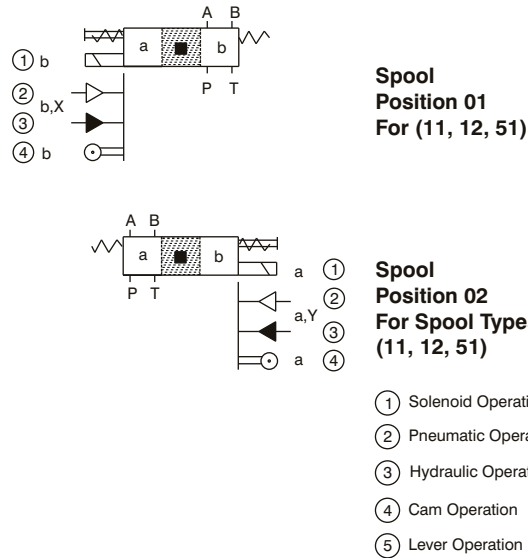

- ① Solenoid Operation
- ② Pneumatic Operation
- ③ Hydraulic Operation
- ④ Cam Operation
- ⑤ Lever Operation

3 Position Detent

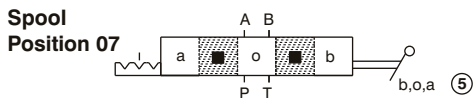

2 Position Detent

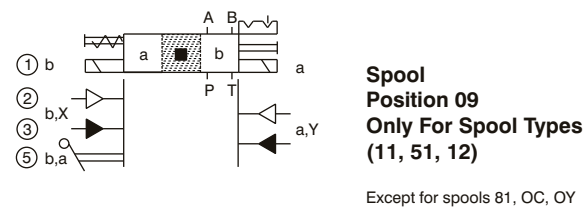

Spool Types Caps

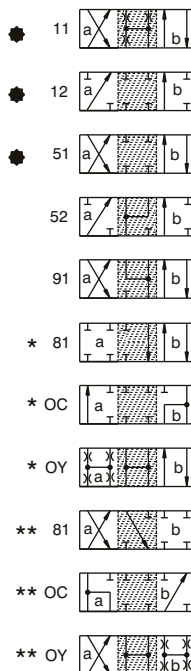
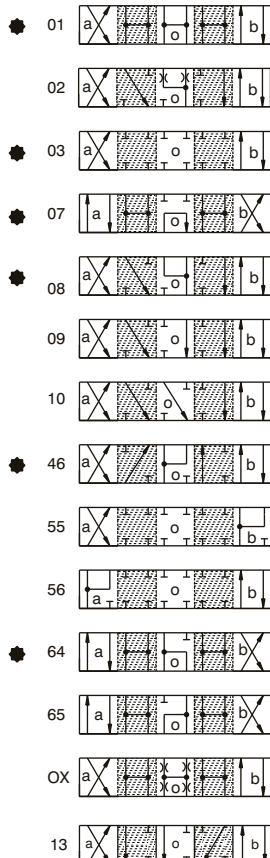

- Standard Spools
- * Spool Position 01 only
- ** Spool Position 02 only

DC

ORDERING CODE

V4D01 - 3202 - 0701 - B1 W07 - ** ** *

Series

Cetop 03

Body

- 3 = Standard (not for spools 55,56)
- F = only for spools 55,56
- H = Bottom connection for Hyd. Operation

Control

- 1 = 1 Solenoid
- 2 = 2 Solenoids
- 4 = Lever Operated
- 5 = Cam Operated
- *7 = 2 solenoids, 2 pos. detents
- D = Pneumatic operation, one-sided
- E = Pneumatic operation, both sides
- *F = Pneumatic operation, both sides (2 pos. detents)
- Q = Hydraulic operation, one-sided
- R = Hydraulic operation, both sides
- *S = Hydraulic operation, both sides (2 pos. detents)
- *(ONLY FOR SPOOLS 11, 12, 51, 52 AND 91)

Spool Type

Refer to page No. 4

Spool Position

- 01=2(a,b),Spring offset pos. "b"; activated to "a"
- 02=2(a,b),Spring offset pos. "a"; activated to "b"
- 03=3(a,o,b),Spring centered pos. "o"
- 05=2(o,b),Spring centered pos "o"; activated to "b"
- 06=2(o,a),Spring centered pos. "o"; activated to "a"
- 07=3 pos. detents (for control 4 only)
- 09=2 pos. detents (for control 4,7,F & S)

End Cap

- 01 = for control 1,D,Q
- 02 = for control 2, 7, E, F, R & S
- 04 = for control 4 & 5
- 05 = for control 4 & spool position 07 & 09
- OH = for control 1 with inductive detector: "a" or "b" position controlled

Valve Accessories / Modifications

- 08 = Orifice of 0,8 mm dia in P-port
- 10 = Orifice of 1,0 mm dia in P-port
- 12 = Orifice of 1,2 mm dia in P-port
- 27 = Plug-in connector
- 28 = Wiring box and flying leads w/o terminal strip
- 38 = Plug-in connector and manual override and orifice 1mm dia. in P-port
- 49 = Wiring box and Brad Harrison Connector
- 51 = Plug-in connector, manual over-ride and indicator lamps
- 52 = Plug-in connector and manual over-ride and rubber cover
- 61 = Wiring box and indicator lamps
- 62 = Wiring Box with indicator lamps and Brad Harrison Connector
- 81 = Wiring Box and flying leads with terminal strip
- G3 = Anchor tube with manual overide and soft shift orifice (only DC)

Solenoid Voltage

(Omit for controls 4,5,D,E,F,Q,R,S)

- W01 = 115V/60 CY AC GOR = 12V DC
- W02 = 230V/60 CY AC GOQ = 24V DC
- W06 = 115V/50 CY AC
- W07 = 230V/50 CY AC
- W54 = 110V/50 CY AC
- W57 = 220V/50 CY AC

Seal Class

- 1 = NBR-seals (Standard)
- 5 = FPM-seals (Viton)

Design Letter

B

DC

FUNCTIONAL LIMITS

Valve with Standard DC-solenoid

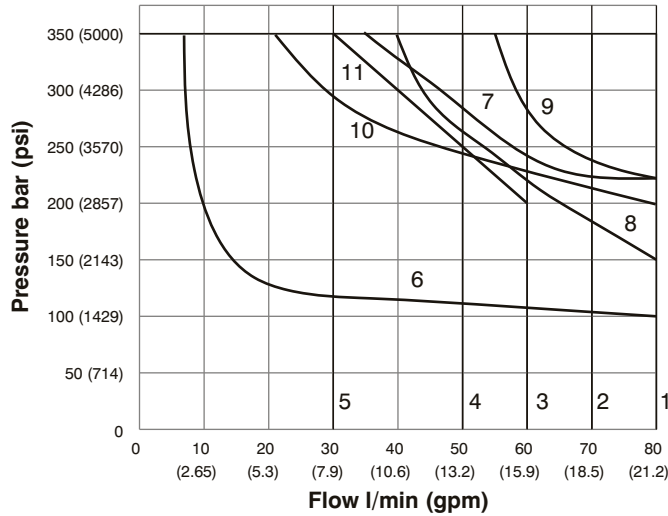

Functional Limits are with warm solenoid operated at 10 undervoltage. The flow data corresponds to 2 flow directions (eg. P to B and simultaneously from A to T). In case of single flow direction only (4-Way-Valve used as 3-Way-Valve) the permissible flow must be reduced.

DC

Valve with Standard AC-solenoid

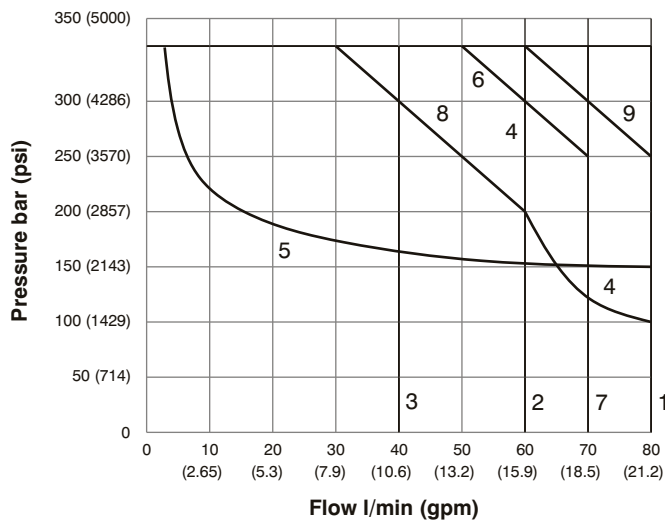

	DC	AC
Spool type	Curve no.	
01	4	2
02	9	6
03	1	2
07	5	3
08	7	2
09	10	7
10	10	7
11	2(1)	1
12 ¹⁾	6(8)	5
46	3	4
51	2(1)	2
52	6(8)	5
55	9	9
56	9	9
64	5	3
65	5	3
81	3	1
91	(1)	1
OC	1	1
OY	11	8
OX	11	8

() Curves for spool with detents
 1) Only if port A and B is closed

1 & 2 - SOLENOID AC / DC OPERATED VERSIONS 3 PIN CONNECTOR

Weight				
	Single Solenoid		Double Solenoid	
AC	3.8 lbs	(1.73Kg)	4.2 lbs	(1.91 Kg)
DC	4.2 lbs	(1.91Kg)	4.5 lbs	(2.05 Kg)

Tighting Torque : 9NM (Approx)

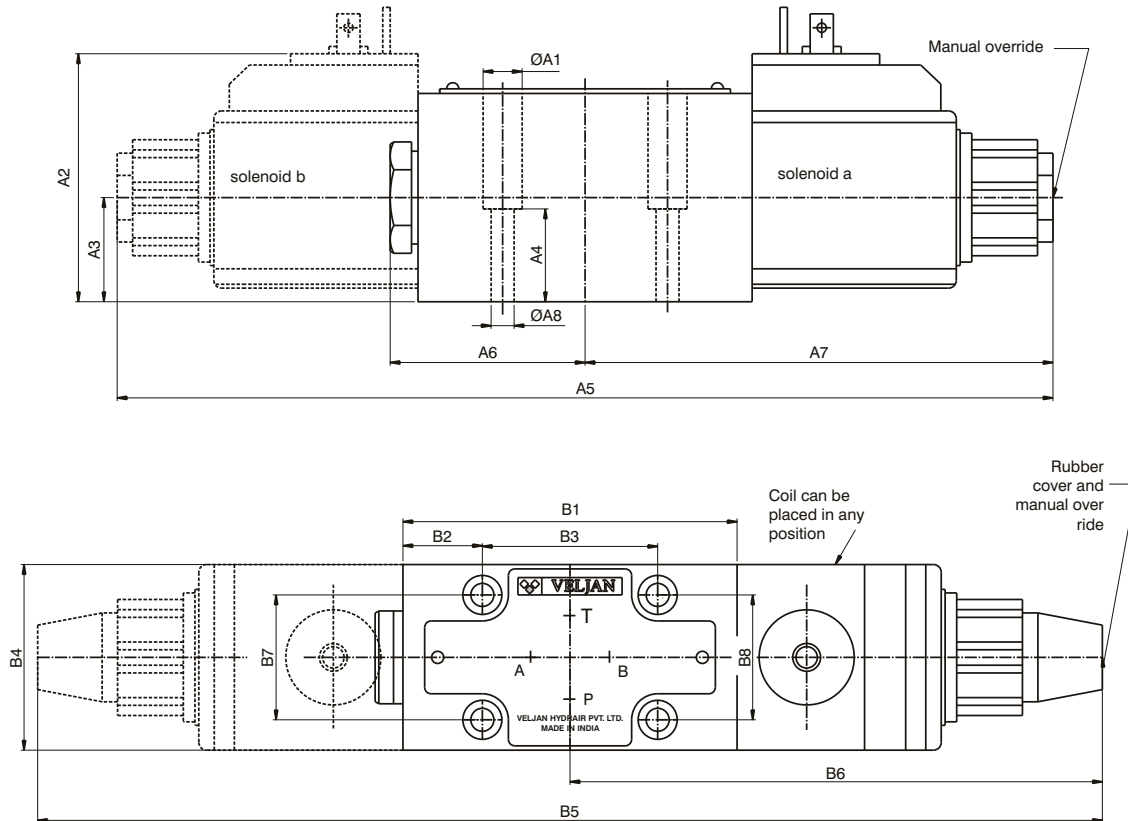

DC

	Dimensions	
	in	mm
A1	Ø0.35	Ø9.0
A2	2.28	58.0
A3	0.94	24.0
A4	0.87	22.0
A5	8.78	223.0
A6	1.77	45.0
A7	4.72	111.5
A8	Ø0.21	Ø5.3

	Dimensions	
	in	mm
B1	3.03	77.0
B2	0.67	17.0
B3	1.59	40.5
B4	1.77	45.0
B5	10.40	264.0
B6	5.20	132.0
B7	1.22	31.0
B8	1.28	32.5

Plug-in connectors according to ISO 4400

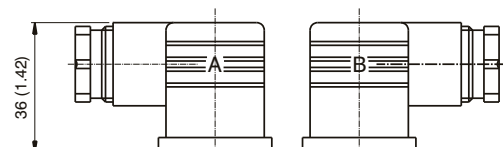

Port Functions:

P = Pressure
T = Tank
A+B = User

Versions	ISO 4400	A-Side	B-Side
Standard	PG11	V 167-01007-8	V 167-01008-8
Voltage >250V	PG11	V 167-01019-8	V 167-01020-8
with LED (red) 15 ... 30V		V 167-01100-8	V 167-01101-8
with bridge rectifier 12 ... 250V		V 167-01076-8	V 167-01014-8

1 & 2 - SOLENOID AC / DC OPERATED VERSIONS WIRING BOX

Weight				
	Single Solenoid		Double Solenoid	
AC	5.1 lbs	(2.33 Kg)	5.5 lbs	(2.51 Kg)
DC	5.5 lbs	(2.51 Kg)	5.8 lbs	(2.65 Kg)

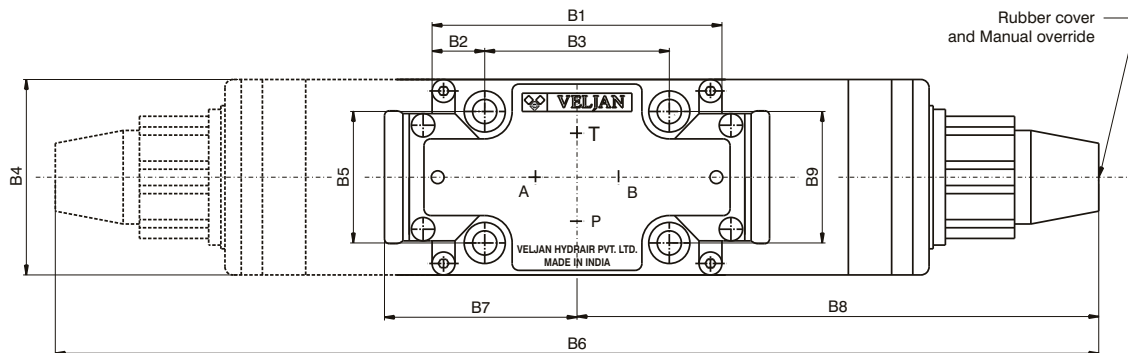
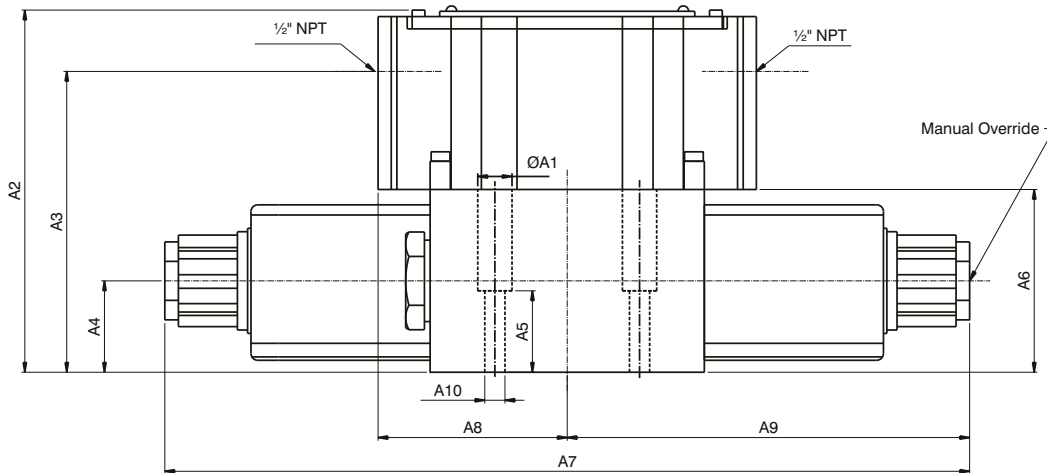

DC

Port Functions:

- P = Pressure
- T = Tank
- A+B = User

	Dimensions	
	in	mm
A1	Ø0.35	Ø9.0
A2	4.00	101.5
A3	3.13	79.5
A4	0.94	24.0
A5	0.87	22.0
A6	1.95	49.5
A7	9.02	229.0
A8	2.01	51.0
A9	4.51	114.5
A10	Ø 0.21	Ø 5.3

	Dimensions	
	in	mm
B1	3.03	77.0
B2	0.67	17.0
B3	1.59	40.5
B4	1.77	45.0
B5	1.22	31.0
B6	10.4	264.0
B7	5.20	132.0
B8	2.01	51.0
B9	1.28	32.5

LEVER OPERATED VERSION

		Applicable for spool numbers
Functional Limits at 350 bar (5000 psi)	15,9 GPM (60 l/min)	01, 02, 03, 08, 09, 10, 46, 55, 56, OX
	10.6 GPM (40 l/min.)	07, 64, 65
Operating force	30 Newtons (6.7 lbs)	
Angle of operation	±17.5°	
Max. Tank Pressure	160 bar (2300 psi)	
Weight	3.8 lbs (1.73 kg)	

Dimensions		
	in	mm
A1	Ø0.35	Ø9.0
A2	1.59	40.5
A3	1.59	40.5
A4	2.09	53.0
A5	0.95	24.0
A6	0.87	22.0
A7	5.55	141.0
A8	Ø0.21	Ø5.3

Dimensions		
	in	mm
B1	3.03	77.0
B2	0.68	17.0
B3	1.59	40.5
B4	1.77	45.0
B5	1.08	27.5
B6	5.65	143.5
B7	3.88	98.5
B8	1.22	31

Port function
 P = Pressure
 T = Tank
 A+B = User

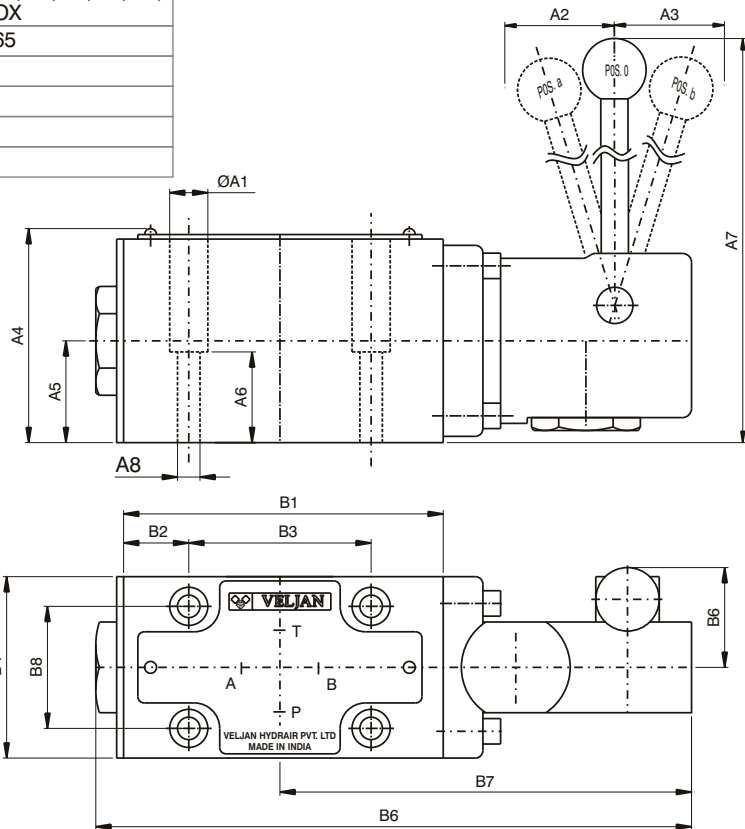

CAM OPERATED VERSION

		applicable for spool numbers
Functional Limits at 350 bar (5000 psi)	15,9 GPM (60 l/min)	01, 02, 03, 08, 09, 10, 11, 46, 51, 55, 56, 81, 91, 0C
	9.3 GPM (35 l/min.)	07, 64, 65, OY, OX
	2.6 GPM (10 l/min.)	12, 52
Weight	3,1 lbs (1.41 Kg)	

	Operating Force Newtons (lbs) at operating pressure bar (psi)		
	100 (1430)	200 (2860)	350 (5000)
Without Tank Pressure	100 (22.5)	120 (27.0)	140 (31.5)
With Tank Pressure Max. 20 bar (286 psi)	160 (36)	180 (40.5)	200 (45.0)

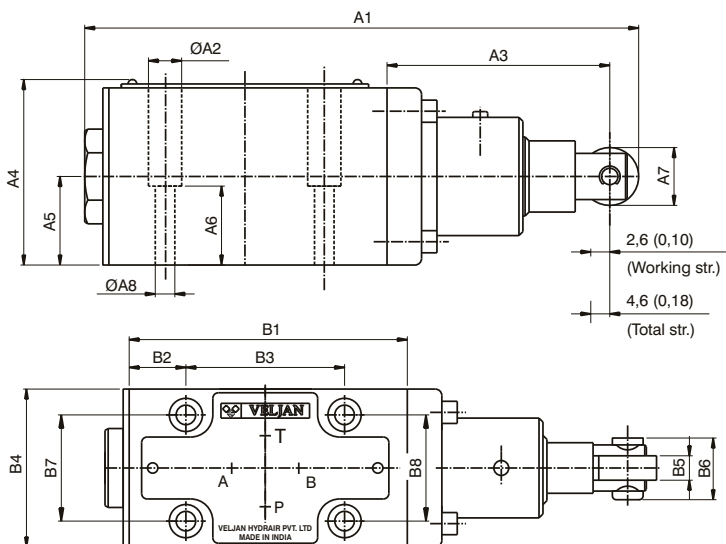

Dimensions		
	in	mm
A1	6.46	164.2
A2	Ø0.35	Ø9.0
A3	2.74	69.7
A4	1.97	50.0
A5	0.95	24.0
A6	0.87	22.0
A7	0.87	22.0
A8	Ø0.21	Ø5.3

Dimensions		
	in	mm
B1	3.03	77.0
B2	0.68	17.0
B3	1.59	40.5
B4	1.77	45.0
B5	0.31	8.0
B6	0.87	22.0
B7	1.22	31.0
B8	1.28	32.5

Port Functions:
 P = Pressure
 T = Tank
 A+B = User

DC

PNEUMATICALLY OPERATED VERSION

Functional Limits
at 350 bar (5000 psi)

15.9 GPM (60 l/min) (for spools 01, 02, 03, 08, 09, 10, 11, 46, 51, 55, 56, 81, 91, OC)
9.3 GPM (35 l/min) (for spools 07, 64, 65, 0Y, 0X)
2.6 GPM (10 l/min) (for spools 12, 52)

Pilot Pressure

- w/o tank pressure
- 160 bar (2300 psi) tank pressure

min. 4 bar (58 psi)
min. 6 bar (87 psi) / max. 12 bar (174 psi)

Pilot volume (each side)

0.195 in³ (3,2 cm³)

1) Response Time

-on

20....200 ms

-off

20....200 ms

1) depending on pilot pressure and pipe length

Weight

-operated one side
-operated both sides

3.8 lbs (1.73 Kg)

5.1 lbs (2.33 Kg)

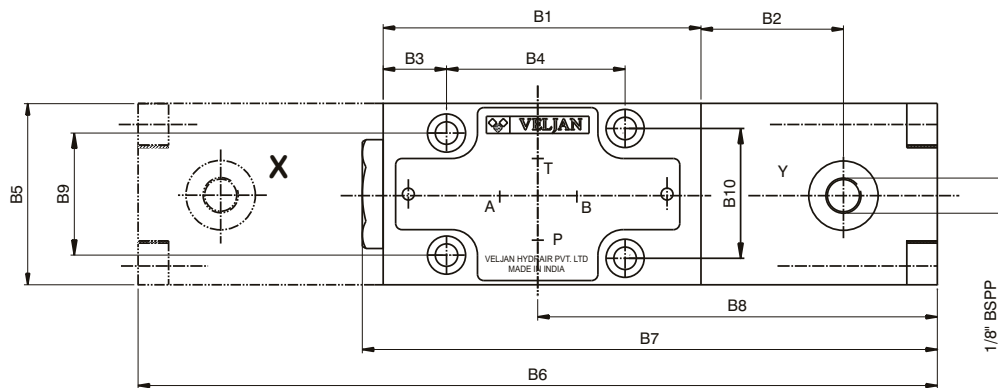
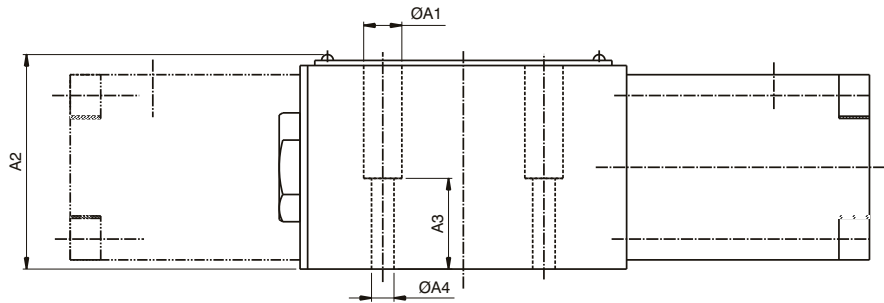

DC

Dimensions

	in	mm
B1	3.03	77.0
B2	1.57	40.0
B3	0.68	17.0
B4	1.59	40.5
B5	1.77	45.0
B6	7.13	181.0
B7	5.33	135.5
B8	3.56	90.5
B9	1.22	31.0
B10	1.28	32.5

Dimensions

	in	mm
A1	$\varnothing 0.35$	$\varnothing 9.0$
A2	1.97	50.0
A3	0.87	22.0
A4	$\varnothing 0.21$	$\varnothing 5.3$

Port Functions:

P = Pressure
T = Tank
A+B = User
X+Y = Pilot Ports

HYDRAULICALLY OPERATED VERSION

Functional Limits
at 350 bar (5000 psi)

15.9 GPM (60 l/min) (for spools 01, 02, 03, 08, 09, 10, 11, 46, 51, 55, 56, 81, 91, OC)
9.3 GPM (35 l/min) (for spools 07, 64, 65, 0Y, 0X)
2.6 GPM (10 l/min) (for spools 12, 52)

Pilot Pressure

Minimum
Maximum

min. 145 psi (10 bar) > tank pressure
max. 3000 psi (200 bar)

Pilot volume (each side)

0.061 in³ (1 cm³)

Response Time ¹⁾

(at Pilot pressure of 50 bar (714 psi)

-on

50....100 ms

-off

60....160 ms

1) depending on pilot pressure and pipe length

Weight

-operated one side
-operated both sides

3.6 lbs (1.64 Kg)

4.8 lbs (2.2 Kg)

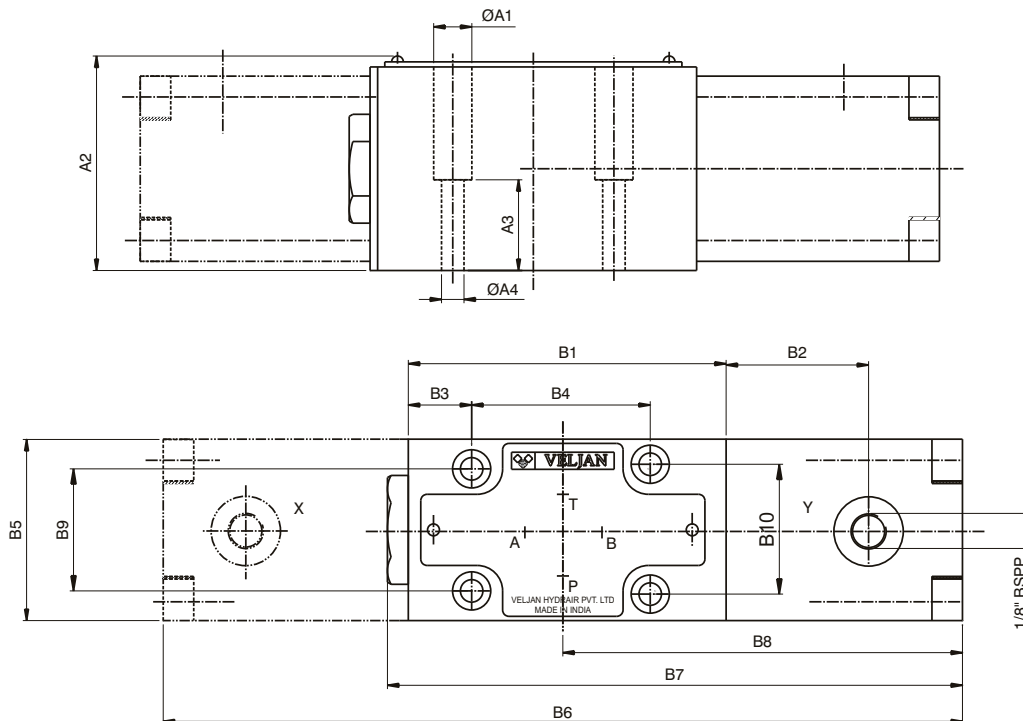

DC

Port Functions:
P = Pressure
T = Tank
A+B = User
X+Y = Pilot Ports

Dimensions		
	in	mm
A1	Ø0.35	Ø9.0
A2	1.97	50.0
A3	0.87	22.0
A4	Ø0.21	Ø5.3

Dimensions		
	in	mm
B1	3.03	77.0
B2	1.18	30.0
B3	0.68	17.0
B4	1.59	40.5
B5	1.77	45.0
B6	6.34	161.0
B7	4.94	125.5
B8	3.17	80.5
B9	1.22	31.0
B10	1.28	32.5

SOFT SHIFT VERSION, OPTION G3

VELJAN make CETOP 3 soft shift version (option G3) has special solenoids that permit a multiple increase of solenoid response time.

Option G3 provides:

- Reduced pressure shocks in venting operations.
- Reduced system noise during spool transition.
- Increased lifetime of the valve and system.

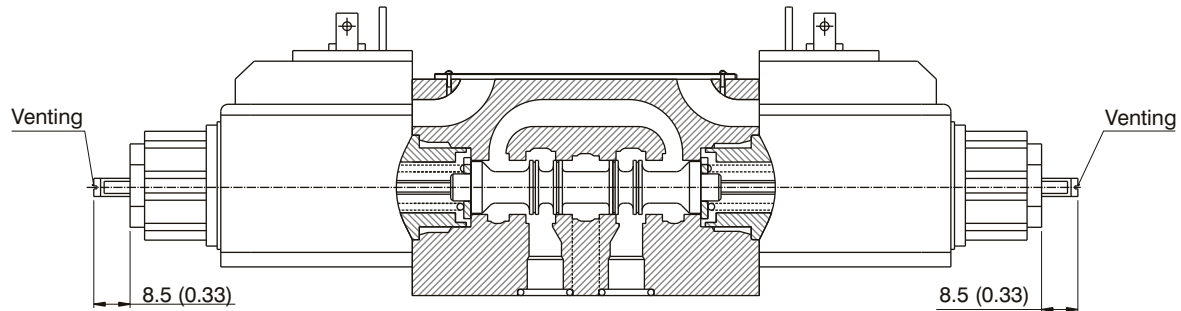

Circuit Design

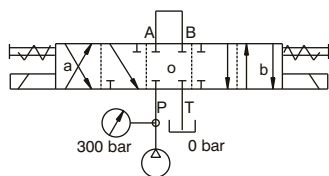

Example pressure unloading P to A :
 300 bar (4285 psi) ; 15.9 gpm (60 l/min) ;
 36cST; 120 °F (50°C)
 V4D01-3-2-03-03-02-B-1- GOQ-G3

Pressure shift sequence of spool stroke o to a or o to b.

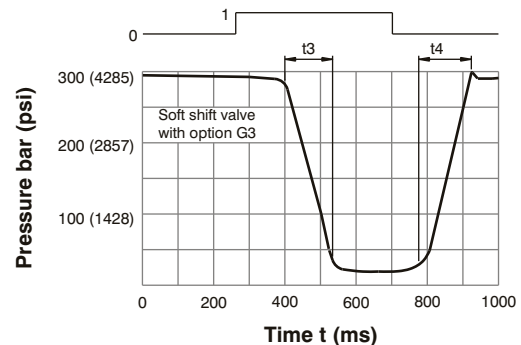
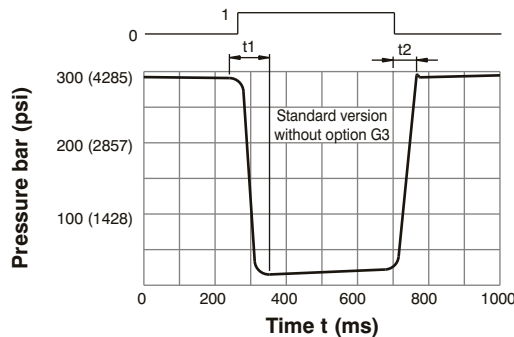

Response times (ms) for 24 V DC Solenoid

	t1	t2	t3	t4
Spool stroke	35...40	55...60	300...500	400...800
Pressure change	20...25	35...40	80...200	80...400

Note:
 Response time will be influenced by changes in viscosity, pressure or flow.

Note:

1. The functional limit of soft shift version will be reduced by as much as 25 from standard, depending on the spool type.
2. The solenoid tube cartridges must remain filled with oil at all times. The tube cartridges are provided with venting screws (see above) to remove air during initial start up. It is recommended to use a check valve (1...2 bar) (14-28 psi) in the tank line to prevent draining of oil from solenoid tube cartridges especially when valve is mounted above the oil level.

MOUNTING CONFIGURATION (ACCORDING TO CETOP, ISO AND DIN)

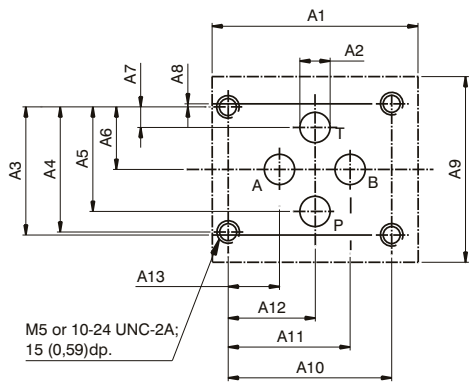

Dimensions	in mm	
	in	mm
A1	2.0	51.0
A2	0.30	7.5
A3	1.25	31.75
A4	1.22	31.0
A5	1.02	25.9
A6	0.61	15.5
A7	0.20	5.1
A8	0.03	0.75
A9	1.81	46.0
A10	1.59	40.5
A11	1.19	30.2
A12	0.85	21.5
A13	0.50	12.7

Block mounting face

Flatness 0.01 mm / 100 mm length

Surface finish $\sqrt{0.8}$

For valves ordered without subplate, mounting screws must be ordered separately.

4-Mounting screws	Order-No.
M5 x 30, DIN 912; 10.9	V700-70834-8
or	
10-24 UNC-2A x 1 1/4" (SAE)	V358-10183-8

Torque 8.3 Nm

Subplates

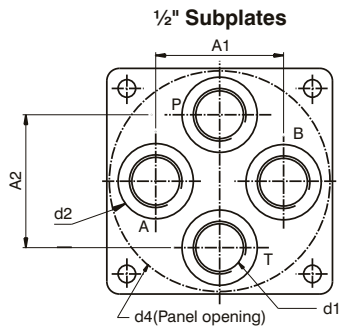

Dimensions	in mm	
	in	mm
A1	2.0	51.0
A2	2.08	53.0

1/4" & 3/8" Subplates

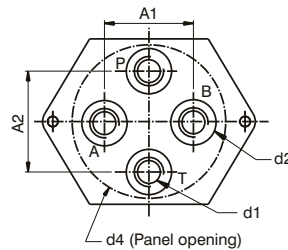

() dimensions in brackets are for 3/8" subplates

Dimensions	in mm	
	in	mm
A1	1.57(1.81)	40(46)
A2	1.73(1.81)	44(46)

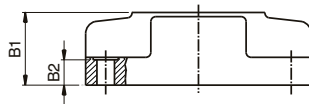

Dimensions	in mm	
	in	mm
B1	1.34	34.0
B2	0.55	14.0

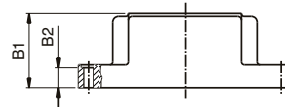

Dimensions	in mm	
	in	mm
B1	1.18	30.0
B2	0.39	10.0

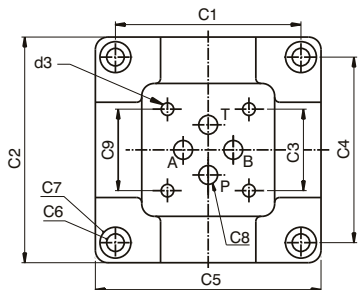

Dimensions	in mm	
	in	mm
C1	2.91	74.0
C2	3.54	90.0
C3	1.27	32.5
C4	2.91	74.0
C5	3.54	90.0
C6	Ø0.27	Ø7.0
C7	Ø0.47	Ø12.0
C8	Ø0.29	Ø7.5
C9	1.22	31.0

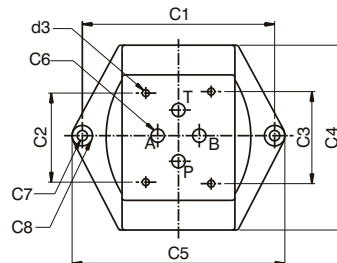

Dimensions	in mm	
	in	mm
C1	3.54	90.0
C2	1.22	31.0
C3	1.28	32.5
C4	3.15	80.0
C5	4.13	105.0
C6	0.30	Ø7.5
C7	Ø0.28	Ø7.0
C8	Ø0.47	Ø12.0

Model no.	Order no.	Weight	d1 (A,B,P,T)	d2	Thread for Mounting Screws d3	d4
VSS-B-04-G 136	VS26-32959	3.1 lbs (1.4 kg)	G 1/4"	Ø23x1 dp.	M5	Ø76(2.99)
VSS-P-04-G 135	VS26-32962	3.1 lbs (1.4 kg)	1/4" NPTF	—	10-24 UNC-2A	Ø76(2.99)
VSS-B-06-G 136	VS26-32960	3.1 lbs (1.4 kg)	G 3/8"	Ø26x1 dp.	M5	Ø79(3.11)
VSS-B-08-G 136	VS26-32961	3.7 lbs (1.7 kg)	G 1/2"	Ø31x1 dp.	M5	Ø88(3.46)
VSS-P-08-G 135	VS26-32963	3.7 lbs (1.7 kg)	1/2" NPTF	—	10-24 UNC-2A	Ø88(3.46)

THIS PAGE INTENTIONALLY LEFT BLANK