

**Directional Control Valves  
4D03**

**THIS PAGE INTENTIONALLY LEFT BLANK**

VELJAN model V4D03 is a pilot operated Directional Control valves conform to NFPA D07, CETOP 07 standard interface . These are subplate and manifold mounted and can be used in conjunction with stack valve systems. The valve mounting interface and electrical connection methods conform to international standards CETOP, ISO, DIN. The coils used in the wet pin design solenoids are available in A.C. and D.C. voltages and are continuously rated . Precise guide for all types of spools are achieved by uniquely designed eight annuli body. Spools are interchangeable and no selective assembly is necessary. Streamlined internal channels ensure minimum pressure drop at maximum flow.

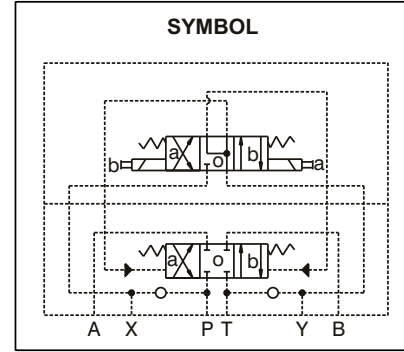

## Features

- ◆ Extremely low pressure drop.
- ◆ High functional limit up to 80 gpm (300l/min) at nominal pressure.
- ◆ Mounting configuration according to CETOP R35H, ISO 4401 and DIN 24340.
- ◆ Nominal operating pressure 350 bar (5000 psi).
- ◆ Interchangeability of spools & bodies due to high precision manufacturing processes.
- ◆ Actuated by electrical / hydraulic / pneumatic / cam or lever mechanism.
- ◆ Wide range of A.C. and D.C. coil voltages are available both with or without manual override.
- ◆ Wide variety of spools available.
- ◆ Change of solenoid coil is fast and simple without risk of oil leakage.
- ◆ Versions with shifting time adjustment, main valve with adjustable spool stop and position control by inductive detector available.
- ◆ Permissible pressure in the tank port up to 350 bar (5000 psi) with external drain, up to 210 bar (3000 psi) with internal drain (see characteristics).

DC

## OPERATION

The electrically operated 4-way valve 4D03 consists of a main body and a solenoid operated pilot valve. The energized solenoid shifts the pilot control spool, thus directing fluid to one end of the main spool, and moving it to the desired position. Fluid can then flow e.g. from port P to either port A or B whilst the alternate port (B or A) is connected to the tank line. The necessary pilot pressure can be obtained internally from the system port P or from an external pressure supply connected to port X. De-energizing the solenoid allows both the pilot control and the main spool to return to their neutral positions. The hydraulically operated version may be remotely controlled by an external pilot valve. The main spool of the direct operated valves can be moved mechanically by means of a lever or stem.

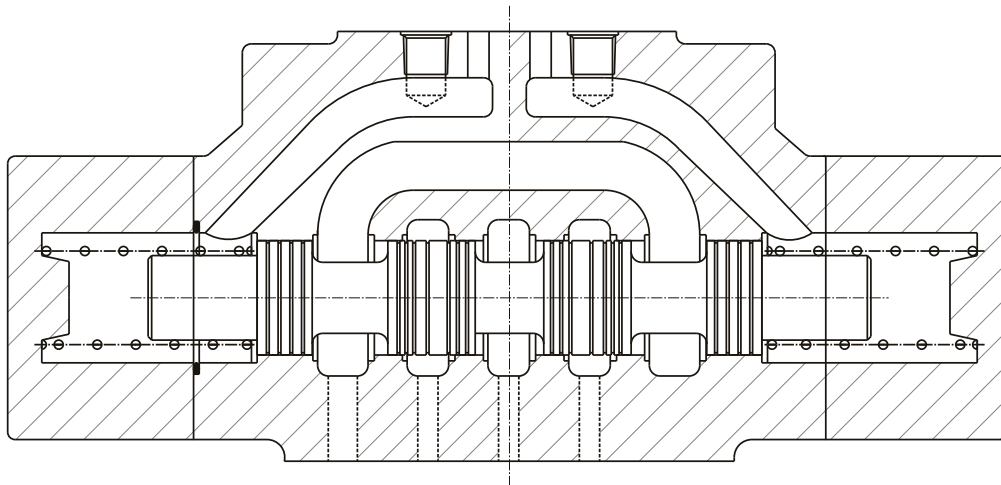
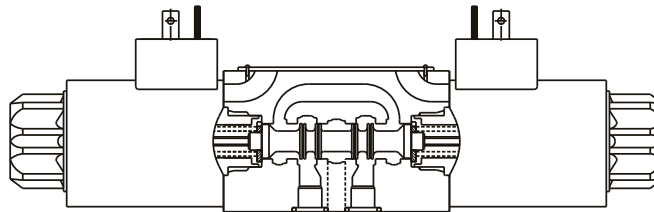
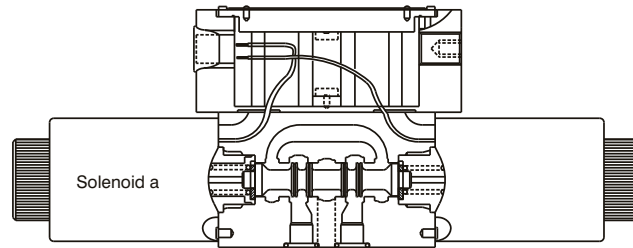

DC

## Orifice

In certain operating conditions, a flow greater than the functional limit of the pilot valve may be generated. It is recommended that one orifice be fitted in the P port of the pilot valve (code 10 for solenoid operation) or two orifices in the A & B ports of the pilot cap (code P3 for hydraulic operation).

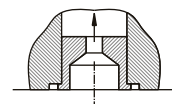

PILOT VALVE ORIFICE

## CHARACTERISTICS

<b>Design</b>	: Sliding spool valve
<b>Type of Mounting</b>	: Subplate conform to NFPA D07, CETOP 07, ISO 4401.
<b>Mounting Position</b>	: Optional
<b>Ambient temperature range</b>	: 0....120°F (-18 ....+50°C)
<b>Operating Pressure(P,A,B,X)</b>	: 350 bar (5000 psi)
<b>External pilot pressure at 80gpm (300l/min)</b>	
<b>-min</b>	: 8.5 bar (125 psi) for spools with open center position : 9.5 bar(140 psi) for spools with closed center position.
<b>-max</b>	: 250 bar(3625 psi) > 250 bar...350 bar(3625 psi.....5000 psi) a pilot orifice dia. 1,0 mm in P-port is recommended (code 10 or P3).
<b>Max. flow</b>	: 80 gpm (300 l/min) see diagram.
<b>Max. leakage (at 350bar)</b>	: Upto 200 ml/min (depends on spool type)
<b>Fluid</b>	: Petroleum base anti-wear fluids . Such as mineral oil according to DIN 51524/25. Maximum catalogue ratings and performance data are based on operation with these fluids. Please contact Veljan Denison engineering team for use with other fluids.
<b>Viscosity range</b>	: 10....650 cSt Optimum 30 cSt
<b>Fluid temperature range</b>	: 0....176°F(-18....+80°C)
<b>Contamination level</b>	: Max. permissible contamination level according to NAS 1638 Class 8 (Class 9 for 15 Micron and smaller) or ISO 17/14.

## SOLENOID CHARACTERISTICS

DC

	A.C.	D.C.
Voltage	See Ordering Code	See Ordering Code
Power Input	22 W	29 W
Holding Power	44 VA	
Inrush Power	198 VA	
Solenoid Response Time		
- solenoid energized	20 ms	46 ms
- solenoid de-energized	18 ms	27 ms
- quick energizing		30 ms (double voltage)
Permissible voltage difference	± 10	± 10
Maximum coil temperature	180 °C (350° F)	180 °C (350° F)
Relative Operating Period	100	100
Type of Protection	IP 65	IP 65
Insulation Class	H	H
Cycle (1/H)	7,200	16,000

## SPOOL TYPES, PRESSURE DROP (PSI), FUNCTIONAL LIMITS (GPM)

### Spool Types

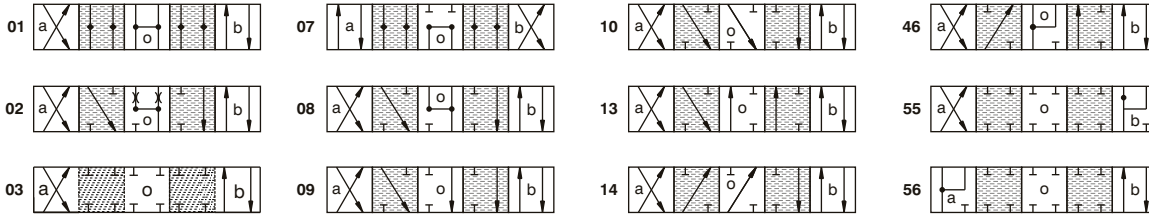

### Pressure Drop

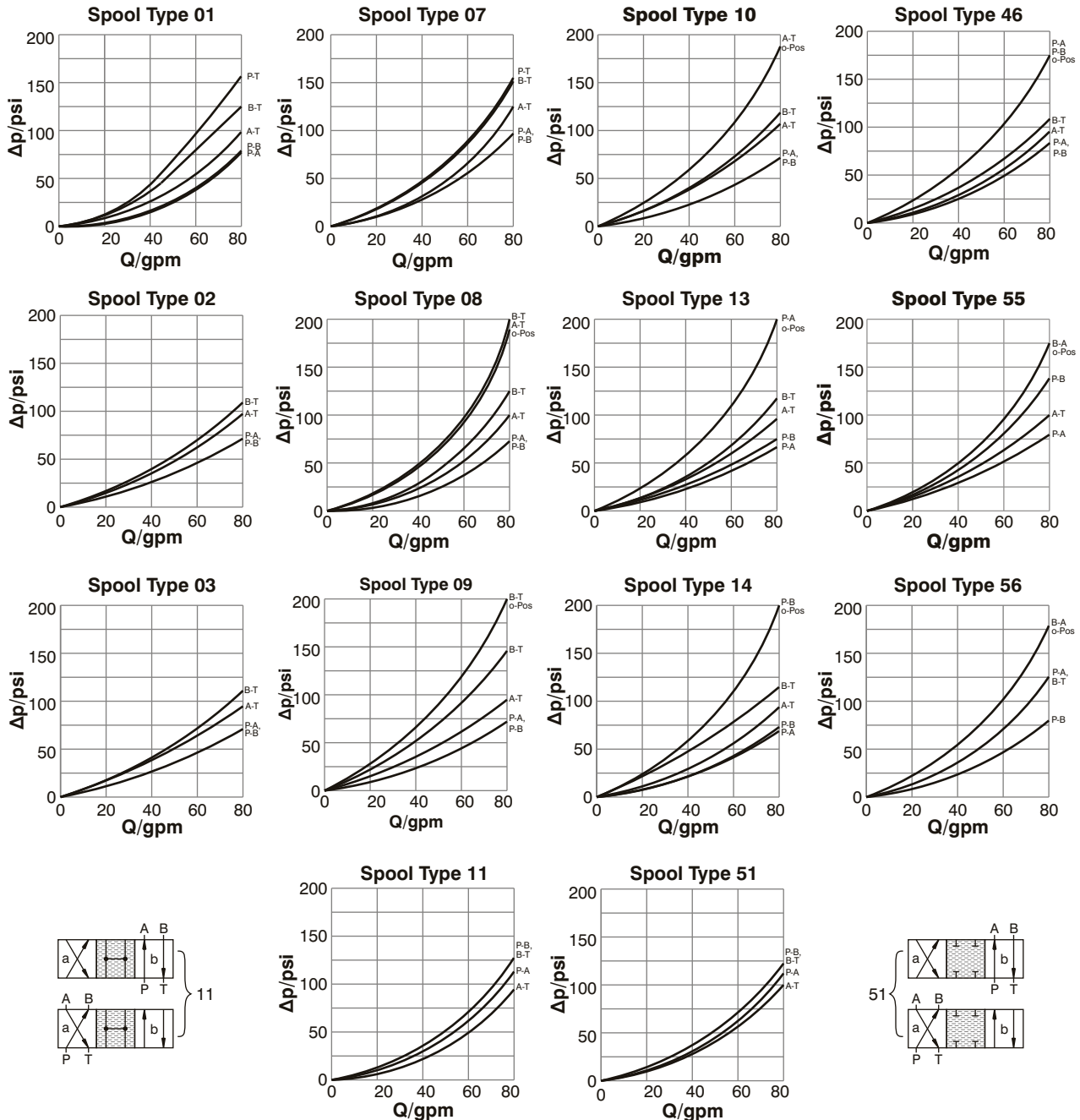

DC

## FUNCTIONAL LIMITS

### FUNCTIONAL LIMITS (GPM)

Spool type	max. Flow (gpm) versus Pressure (psi)				
	1000	2000	3000	4000	5000
02, 03, 08, 09, 10, 13, 14, 46, 55, 56	80	80	80	80	80
07	80	80	74	61	48
11	80	80	80	80 / 53*	80 / 50*
51	80	80 / 53*	80 / 45*	80 / 42*	80 / 26*

### FUNCTIONAL LIMITS (LPM)

Spool type	max. Flow (lpm) versus Pressure (bar)				
	70	140	210	280	350
02, 03, 08, 09, 10, 13, 14, 46, 55, 56	300	300	300	300	300
07	300	300	280	230	180
11	300	300	300	300 / 200*	300 / 190*
51	300	300 / 200*	300 / 170*	300 / 160*	300 / 100*

DC

The "fail safe" flow limits of the spool types 11 & 51 must be reduced at higher operating pressure to comply with "safety regulations" where applicable.

Means: The main spool returns to "spring offset" position only by spring force (without pilot pressure).

## SYMBOLS

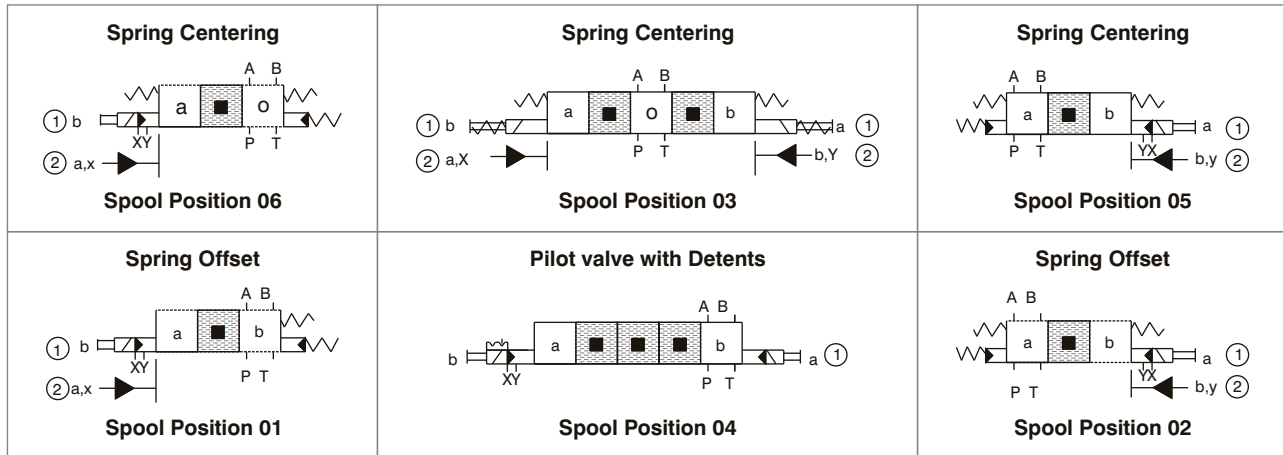

① Solenoid operation

② Hydraulic operation

● Standard Spool

Transfer position only.

DC



## SYMBOLS

**V4D03 3 A51 0103 40A. ...**  
**Spool position 01**  
**2 (a, b), Spring Offset**

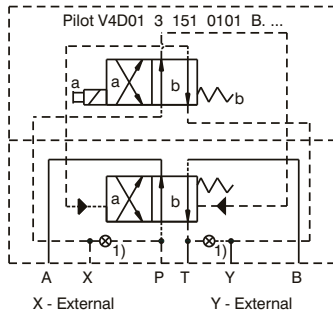

**V4D03 3 A51 0203 40A. ...**  
**Spool position 02**  
**2 (a, b), Spring Offset**

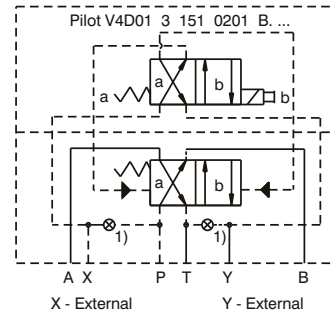

**V4D03 3 B.. 0303 40A. ...**  
**Spool position 03**  
**3(a, o, b), Spring Centering**

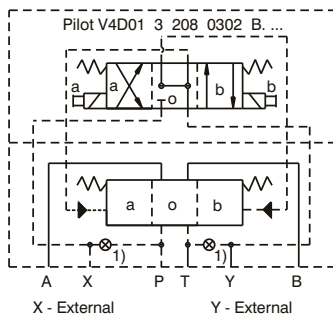

**V4D03 3 C.. 0403 40A. ...**  
**Spool position 04**  
**2 (a, b), Pilot Valve with detents**

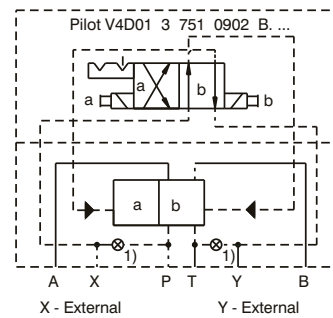

DC

**V4D03 3 A.. 0503 40A. ...**  
**Spool position 05**  
**2 (o,b), Spring Centering**

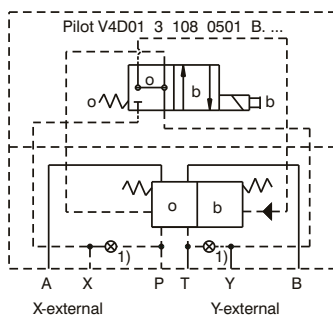

**V4D03 3 A.. 0603 40A. ...**  
**Spool position 06**  
**2 (o,a), Spring Centering**

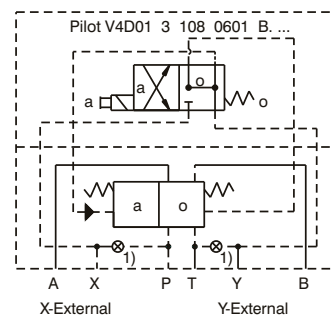

1) Plug mounted according to desired internal or external PP or PD.

## ORDERING CODE

V4D03-3 x xx - xx xx - x x A x xxx - 10 xx xx

### Series

03 = Cetop 07

### Control

A = Pilot operated, 1 solenoid (4D01)  
 B = Pilot operated, 2 solenoid (4D01)  
 C = Pilot operated, 2 solenoid (4D01)  
 Pilot Valve, 2 pos detents  
 O = Hydraulic operated

### Spool Type

Refer to page No. 5,6,7,8

### Spool Position

01=2(a,b),Spring offset to pos. "b"; energized to "a"  
 02=2(a,b),Spring offset to pos. "a"; energized to "b"  
 03=3(a,o,b),Spring centered pos. "o"  
 04=2(a,b),Spool is not centered, energized to "a" or "b"  
 (pilot valve with detents)  
 05=2(o,b),Spring centered pos. "o"; energized to "b"  
 06=2(o,a),Spring centered pos. "o"; energized to "a"

### End Cap

03 = for control A, B, C, O  
 09 = for controls A, B, C, O with adjust spool stop  
 on both sides versions with inductive detector  
 SA = for spool position 01, 02, 03, 05, 06  
 Neutral position controlled  
 SB = for spool position 01, 02, 05, 06 a - or  
 b - position controlled  
 TA = for spool position 03 Neutral position controlled  
 SC = for spool position 03 Both end pos controlled  
 TC = for spool position 03 Both end pos controlled

### Pilot Connection

0 = External PP, external PD  
 (for hydraulic operator)  
 1 = Internal PP, internal PD<sup>1)</sup>  
 2 = Internal PP, external Pd<sup>1)</sup>  
 3 = External PP, internal PD  
 4 = External PP, external PD

### Main Valve Accessories

0 = without  
 1 = Shifting time adjustment (meter in control)  
 2 = Shifting time adjustment (meter out control)  
 6 = Shifting time adjustment (meter in control) & integral check in "P"<sup>1)</sup>  
 8 = Shifting time adjustment (meter out control) & integral check in "P"<sup>1)</sup>  
 4 = Integral check in "P"<sup>1)</sup>

### Note :

1) For valves with spools 01, 07, 11 and internal PP an Integral check is recommended in P-Port of the main body to obtain the minimum pilot pressure  
 The integral check is not provided for load pressure holding back to P-port  
 2) For standard application orifice in P-port always recommended

### Pilot Accessories and Modifications

10 = 1.0 mm orifice in P-port  
 for solenoid with manual override

1028 = 1.0 mm orifice in P-port  
 wiring box with 6" flying leads

1032 = 1.0 mm orifice in P-port  
 for solenoid with manual override

1052 = 1.0 mm orifice in P-port  
 for solenoid with manual override,  
 with rubber cover

102852 = 1.0 mm orifice in P-port  
 wiring box with 6" flying leads  
 & rubber cover

1081 = 1.0 mm orifice in P-port  
 wiring f=g box with 6" flying leads  
 & terminal strips

108152 = 1.0 mm orifice in P-port  
 wiring box with 6" flying leads &  
 terminal strips & rubber cover

P3 = 1.0 mm orifice in  
 A & B-ports of the cap,  
 for hydraulic operation only  
 (control code 0)

### Seal Class

W01 = 115V / 60Hz  
 W02 = 230V / 60Hz  
 W06 = 115V / 60Hz  
 W07 = 230V / 50Hz

G0R = 12 V  
 G0Q = 24 V  
 G0D = 27 V  
 for DIN connector only

### Seal Class

1 = NBR - seal (Standard)  
 4 = EPDM - seals  
 5 = FPM - seal (Viton)

### Design Letter

DC

## 1 & 2 SOLENOID OPERATED VERSIONS, 3 PIN SOCKET

Weight			
Single solenoid		Double solenoid	
AC	DC	AC	DC
9.7 Kg	9.85 Kg	10.15 Kg	10.3 Kg
21.38 lbs	21.7 lbs	22.37 lbs	22.7 lbs

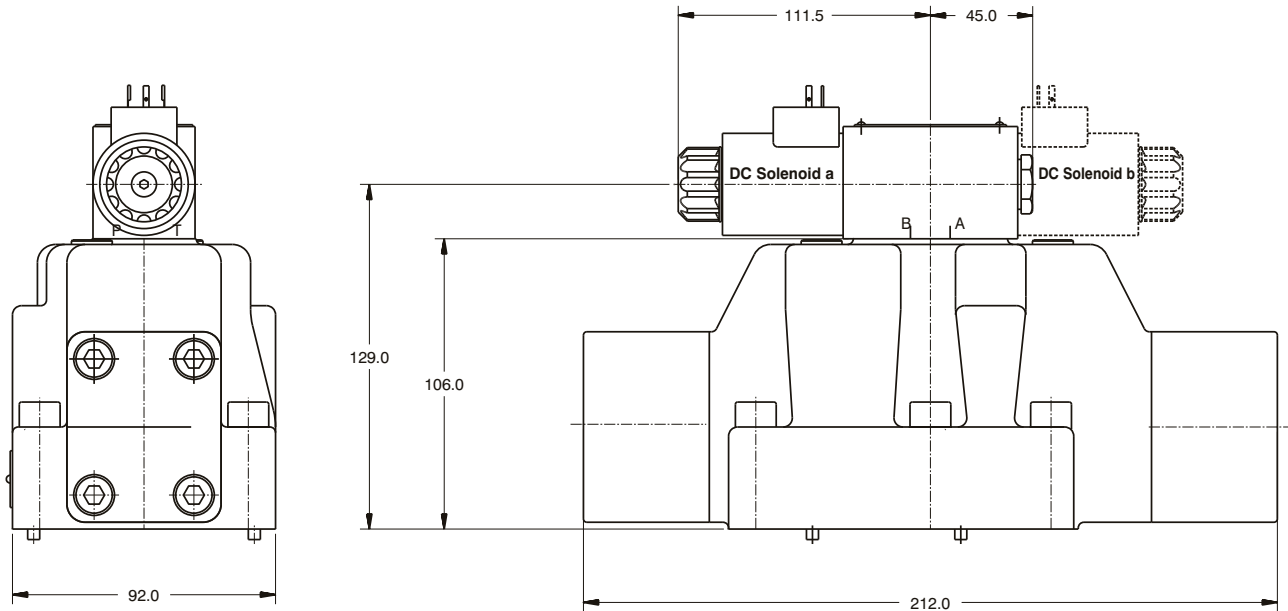

### Plug-in connectors according to ISO 4400

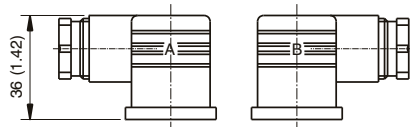

Versions	ISO 4400	A-side(grey)	B-side(black)
Standard <250V	PG11	167-01007-8	167-01008-8
with LED (red) 15 ...30V		167-01100-8	167-01101-8
with bridge rectifier 12...250V		167-01076-8	167-01014-8

Note: Plug-in connectors to be ordered as separate items.

Port function  
 P=Pressure  
 T=Tank  
 A+B=User

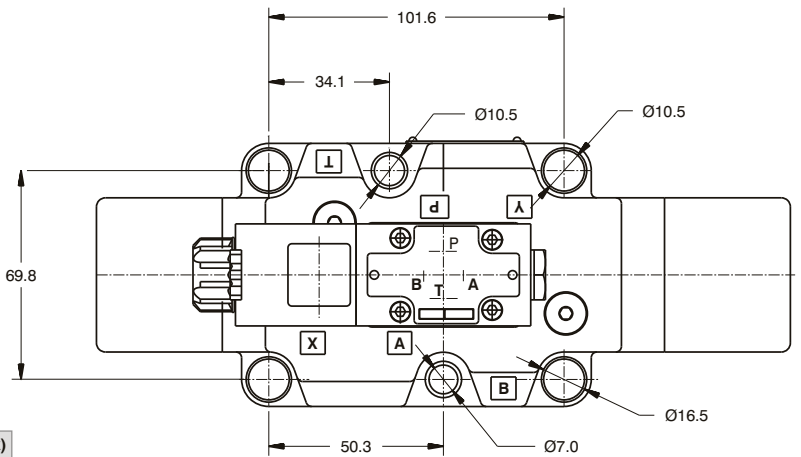

DC

## MOUNTING CONFIGURATION, PLUG-IN CONNECTORS

Mounting configuration confirm to ISO 4401

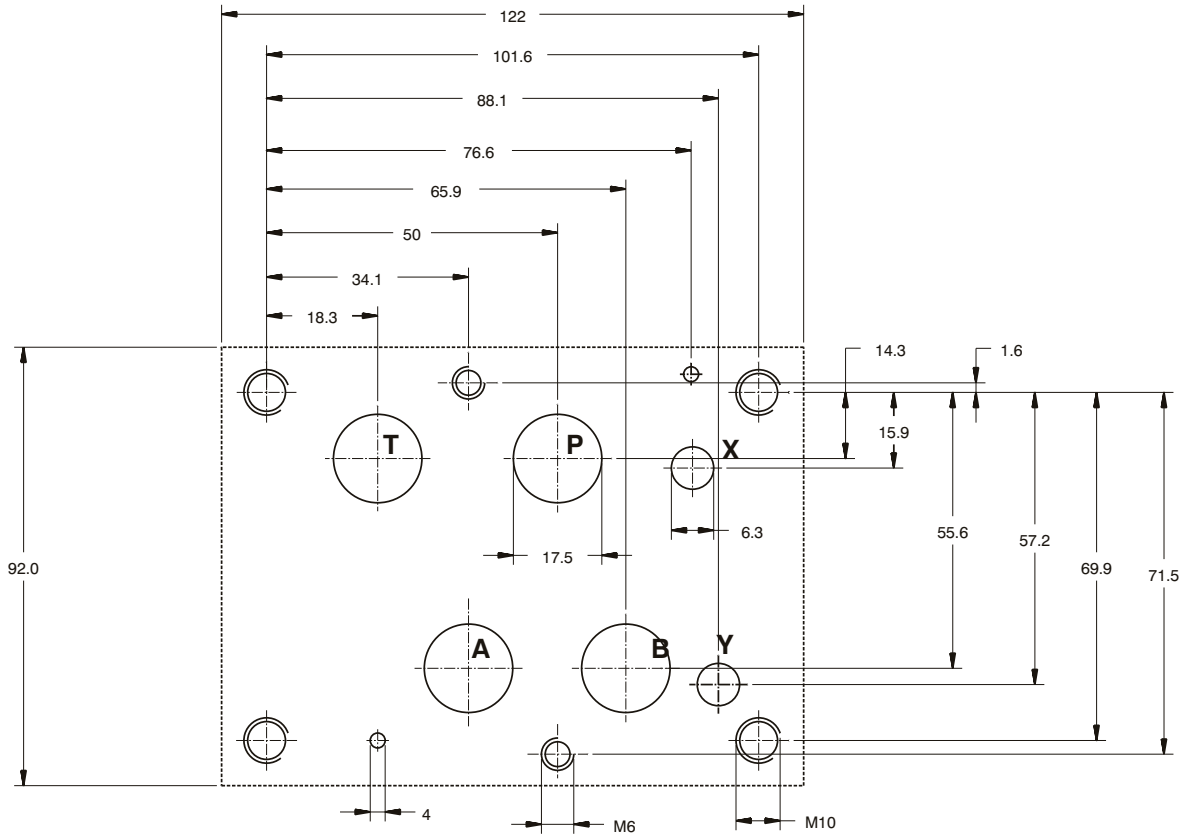

DC

**Block mounting face:-**  
 Flatness 0.01 mm / 100 mm  
 (0,003/3,93 inches) length  
 Surface finish 0.8/

**Portings**

P = Pressure port

T = Tank port

A&B = Actuator ports

X = Pilot port for external  
 PP: pilot operated valves  
 = Pilot port for hydr. operated valves.

Y = Drain port for external  
 = Pilot port for hydr. operated valves.

**Valve Mounting Screws**

Qty.	4 mounting screws	Order-No.
4	M10 X 45 DIN 912;10.9	700-71602
2	M6 X 45 DIN 912;10.9	700-70090

Torque 103 Nm