

VT6CB - 022 - B08-1 R 00 - C 1 - 02 *

Series

Camring for "P1"

Volumetric displacement cm^3/rev (in^3/rev)

*003/B03/Y03 = 10.8 (0.66)	015/B15/Y15 = 50.5 (3.08)
005/B05/Y05 = 17.2 (1.05)	017/B17/Y17 = 58.3 (3.56)
006/B06/Y06 = 21.3 (1.30)	020/B20/Y20 = 63.8 (3.89)
008/B08/Y08 = 26.4 (1.61)	022/B22/Y22 = 70.3 (4.29)
010/B10/Y10 = 34.1 (2.08)	025/B25/Y25 = 79.3 (4.84)
012/B12/Y12 = 37.1 (2.26)	028/B28/Y28 = 88.8 (5.42)
014/B14/Y14 = 46.0 (2.81)	031/B31/Y31 = 100.0 (6.10)

* '0' - Uni - directional 'B' - Bi - directional 'Y' - Bi - directional for cold start

Camring for "P2"

Volumetric displacement cm^3/rev (in^3/rev)

B02 = 5.8 (0.35)	B08 = 24.9 (1.52)
B03 = 9.8 (0.59)	B09 = 28.0 (1.71)
B04 = 12.8 (0.78)	B10 = 31.8 (1.94)
B05 = 15.9 (0.97)	B11 = 34.9 (2.13)
B06 = 19.8 (1.21)	B12 = 41.0 (2.50)(cont. 175 bar, Max. int 210 bar)
B07 = 22.5 (1.37)	B14 = 45.0 (2.75)(cont. 140 bar, Max. int 175 bar)

Type of shaft

- 1- keyed (no SAE)
- 3- splined

Porting combination

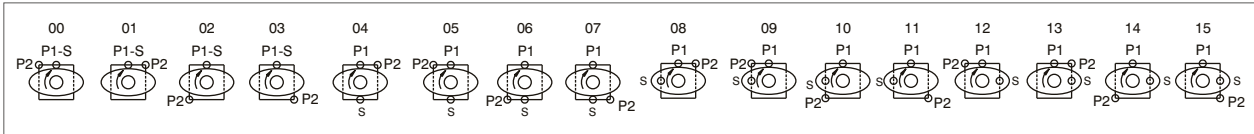

Modifications

Mounting W/connection variables

S = 2 1/2" SAE 4-Bolt Pad.

CODE	P1	P2
01	1" SAE 4 bolt Pad. (UNC)	3/4" SAE 4 bolt Pad. (UNC)
M1	1" SAE 4 bolt Pad. (Metric)	3/4" SAE 4 bolt Pad. (Metric)
02	SAE 16,1 5/16" 12 UNF-2B	SAE 12,1 1/16" 12 UNF-2B

Seal class

- 1 - S1 (for mineral oil)
- 4 - S4 (for fire resistant fluids)
- 5 - S5 (for mineral oil and fire resistant fluids)

Design letter

Porting combination

00 - standard

Direction of rotation (view on shaft end)

R - clockwise

L - counter-clockwise

OPERATING CHARACTERISTICS - TYPICAL (24 cST) (Input power p (KW) for one cartridge only)

Pressure port	Series	Volumetric Displacement Vp		Flow q & n = 1500 rpm						Input power p & n = 1500 rpm					
				p = 0 bar (0 psi)		p = 140 bar (2000 psi)		p = 240 bar (3500 psi)		p = 7 bar (100 psi)		p = 140 bar (2000 psi)		p = 240 bar (3500 psi)	
		in^3/rev	cm^3/rev	gpm	lpm	gpm	lpm	gpm	lpm	hp	kw	hp	kw	hp	kw
P1	003	0.66	10.8	4.29	16.2	2.96	11.2	2.04	7.7	1.74	1.3	7.11	5.3	11.26	8.4
	005	1.05	17.2	6.83	25.8	5.50	20.8	4.57	17.3	1.88	1.4	10.06	7.5	16.36	12.2
	006	1.30	21.3	8.44	31.9	7.11	26.9	6.19	23.4	2.01	1.5	11.94	8.9	19.71	14.7
	008	1.61	26.4	10.48	39.6	9.15	34.6	8.22	31.1	2.15	1.6	14.35	10.7	22.93	17.7
	010	2.08	34.1	13.52	51.1	12.19	46.1	11.26	42.6	2.28	1.7	18.64	13.4	29.90	22.3
	012	2.26	37.1	14.71	55.6	13.36	50.6	12.46	47.1	2.28	1.7	19.31	14.4	32.32	24.1
	014	2.81	46.0	18.25	69.0	16.93	64.0	16.00	60.5	2.55	1.9	23.60	17.6	39.56	29.5
	015	3.08	50.5	20.00	75.6	18.73	73.2	19.02	67.5	2.68	2.0	25.61	19.1	42.91	32.0
	017	3.56	58.3	23.12	87.4	21.79	82.4	20.87	78.9	2.82	2.1	29.37	21.9	49.48	36.9
	020	3.89	63.8	25.32	95.7	23.99	90.7	23.07	87.2	2.95	2.2	31.92	23.8	53.91	40.2
	022	4.29	70.3	27.88	105.4	26.56	100.4	25.63	96.9	3.08	2.3	35.00	26.1	59.14	44.1
	025 ¹⁾	4.84	79.3	31.46	118.9	30.13	113.9	29.21	110.4	3.35	2.5	39.16	29.2	66.38	49.5
	028 ^{1,2)}	5.42	88.8	35.24	133.2	33.92	128.2	33.28	125.8	3.75	2.8	43.85	32.7	65.04	48.5
	031 ^{1,2)}	6.10	100.0	39.68	150.0	38.35	145.0	37.72	142.6	3.75	2.8	48.95	36.5	72.95	54.4
P2				p = 0 bar (0 psi)	p = 140 bar (2000 psi)	p = 210 bar (3000 psi)	p = 7 bar (100 psi)	p = 140 bar (2000 psi)	p = 210 bar (3000 psi)						
	B02	0.35	5.8	2.30	8.7	1.4	5.9	--	--	0.53	0.4	2.81	2.1	--	--
	B03	0.59	9.8	3.88	14.7	2.9	11.9	2.7	10.5	0.67	0.5	3.62	2.7	--	--
	B04	0.78	12.8	5.08	19.2	4.33	16.4	3.97	15.0	0.93	0.7	5.23	3.9	10.06	7.5
	B05	0.97	15.9	6.31	23.8	5.55	21.0	5.18	19.6	1.00	0.75	6.64	4.9	11.2	8.3
	B06	1.21	19.8	7.85	29.7	7.12	26.9	6.66	25.2	1.07	0.8	8.05	6.0	12.34	9.2
	B07	1.37	22.5	8.92	33.7	8.17	30.9	7.80	29.5	1.20	0.9	9.05	6.7	14.02	10.4
	B08	1.52	24.9	9.89	37.4	9.15	34.6	8.78	33.2	1.34	1.0	10.05	7.5	15.69	11.7
	B09	1.71	28.0	11.11	42.0	10.37	39.2	10.00	37.8	1.47	1.1	11.94	8.9	23.60	17.6
	B10	1.94	31.8	12.61	47.7	11.87	44.9	11.51	43.5	1.6	1.2	13.0	9.7	26.0	19.6
	B11	2.13	34.9	13.85	52.3	13.09	49.5	12.72	48.1	1.7	1.3	14.0	10.5	28.0	21.0
	B12	2.50	41.0	16.27	61.5	15.53	58.7	*	*	1.8	1.4	15.02	11.2	*	*
	B14	2.75	45.0	17.86	67.5	17.12	64.7	**	**	2.1	1.6	15.42	11.5	**	**

1) 025-028-031 = 2500 RPM. max. 2) 028-031 = 210 bar (3000 psi) max. int.

*B12 = 210 bar (3000 psi) max. int **B14 = 175 bar (2500 psi) max. int.

- Not to use because internal leakage greater than 50% of theoretical flow.

INTERNAL LEAKAGE (TYPICAL)

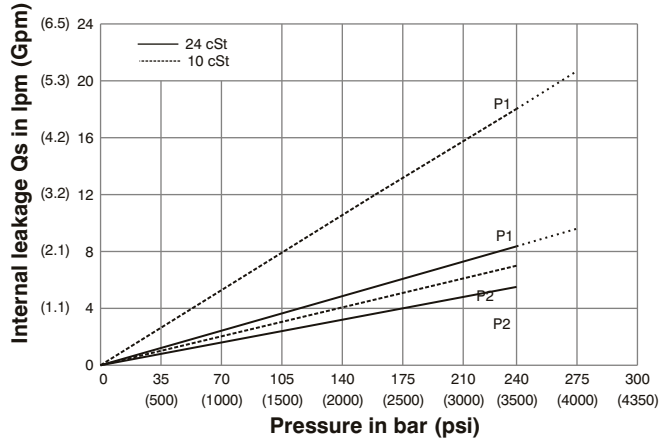

Do not operate pump more than 5 seconds at any speed or viscosity if internal leakage is more than 50% of theoretical flow.
Total leakage is the sum of each section loss at its operating conditions.

NOISE LEVEL (TYPICAL)

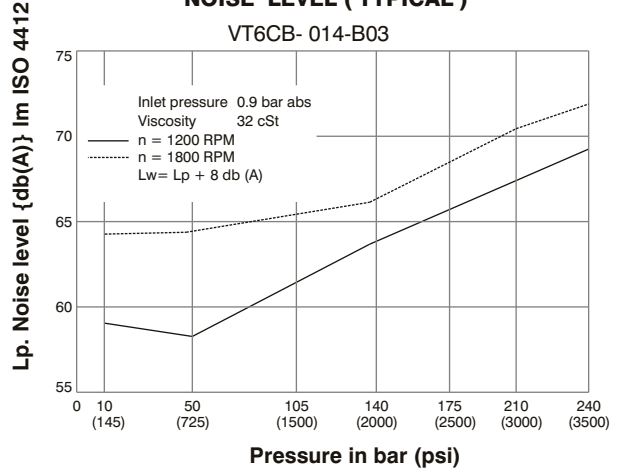

Double pump noise level is given with each section discharging at the pressure noted on the curve.

VP
DP

HYDROMECHANICAL POWER LOSS (TYPICAL)

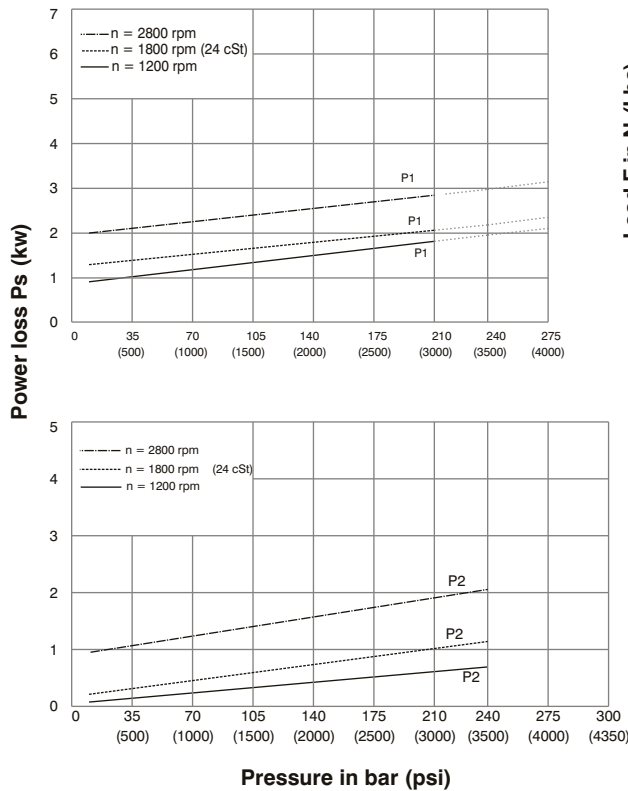

Total hydromechanical power loss is the sum of each section at its operating conditions.

PERMISSIBLE RADIAL LOAD

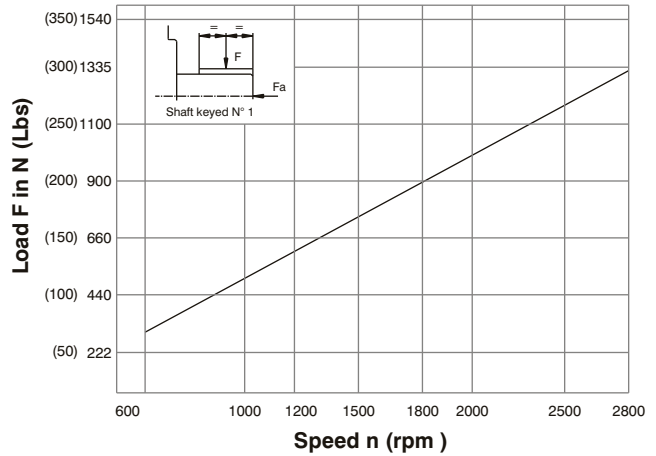

Maximum permissible axial load $F_a = 800\text{N}$ (180 lbs)

VP
|
DP

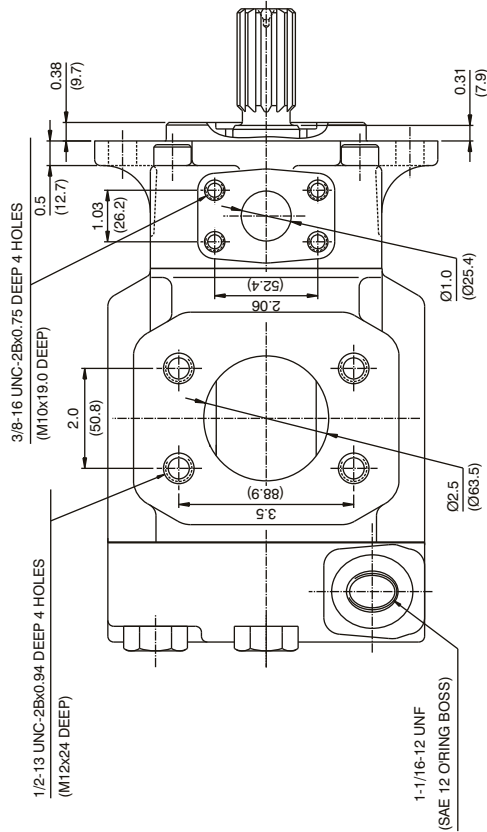
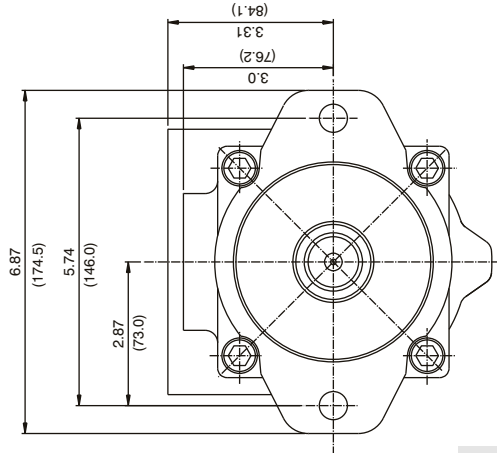
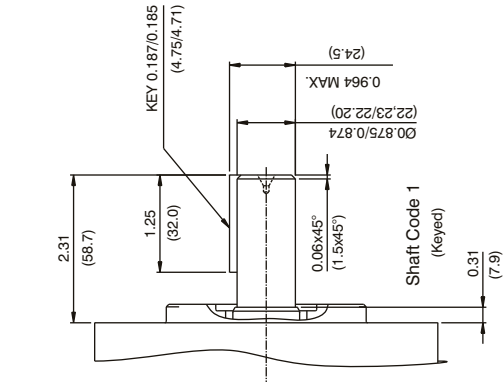

Shaft Code 3
Involute Splined shaft
Class 1-J498b
16/32 d.p 13 teeth
30° press. angle
Major dia. fit

